

Purbanchal University
Faculty of Engineering
 Biratnagar

Second Semester's Course Structure
 Program: Bachelor in Civil Engineering
 Effective from 2021 (2078) Batch

Year-I		Semester-II										
S.N	Course code	Subject	Credit hours	L	T	Pr.	Total	Internal		Final		Total
								Th.	Pr.	Th.	Pr.	
1		Mathematics-II	3	3	3	-	6	40		60		100
2		Physics	4	4	2	2	8	40	10	60	15	125
3		Applied Mechanics-II (Dynamics)	3	3	3	-	6	40		60		100
4		Building Technology	3	3	1	-	4	40		60	-	100
5		Fundamental of Thermodynamics and Heat Transfer	2	2	1	2/2	4	20	25	30	-	75
6		Engineering Drawing II	3	1	-	3	4		60		40	100
		Total	18	16	10	6	32					600

Note- L: Lecture T: Tutorial Pr. : Practical Th. : Theory



Year: I				Semester: II						
Teaching				Examination Scheme						Total Marks
Hours/week				Internal		Final				
				Theory	Practical	Theory		Practical		
Cr	Theory	Tutorial	Practical			Duration	Marks	Duration	Marks	
3	3	3		40		3hrs	60	-	-	100

Objective: The main aim of this course is to provide students a sound knowledge of vector calculus and analytic geometry of 3D to make familiar to the method for testing the convergence of infinite series and give idea to solve differential equations through theoretical explanations and problem solving techniques.

Micro-Syllabus:

Analytic Geometry of 3-D

[12 hrs]

- 1.1 Coordinates in space: Cartesian, cylindrical and Spherical systems, and equations relating to these coordinates, direction ratios and cosines angle between two lines.
- 1.2 Plane: Intercept and normal form of plane, angle between two planes, a plane through three points, plane through the intersection of two planes.
- 1.3 Straight lines: Equations of a line in general and symmetrical forms, angle between two lines, coplanar lines, intersecting lines, shortest distance between two skew lines.
- 1.4 Sphere: Equation of Sphere in standard and general forms, plane section of sphere cut by a plane, tangent plane.
- 1.5 Cone and Cylinder (Right Circular Case)

2. Plane Curves and Polar Coordinates

[6 hrs]

- 2.1 Polar Equation of Conic Section and their sketching
- 2.2 Area arc length, surface area and volume of parametric and polar curves

3. Infinite Series

[6 hrs]

- 3.1 Tests for convergence: Cauchy principle, P-test, limit comparison test, ratio test, root test and integral test.
- 3.2 Alternating series: Absolutely convergent and conditionally convergent.
- 3.3 Power Series: Interval of convergence and radius of convergence

(2)



4. Vector Calculus

[7 hrs]

- 4.1 Differentiation of vector functions.
- 4.2 Integration of vector function.
- 4.3 Gradient, divergence, curl and directional derivatives.

5. Differential Equation

[14 hrs]

- 5.1 First order first degree differential equations: Variable separation method, change of variable, homogeneous differential equations, reducible to homogeneous forms, linear differential equations, Bernoulli's equations, exact differential equations
- 5.2 First order higher degree differential equations: the equation of the form $f(x,y,p) = 0$ where $p = \frac{dy}{dx}$; solvable for p , x and y , Clairaut's form.
- 5.3 Second order differential equations: Linear differential equation with constant coefficients and Cauchy's homogeneous linear equations.
- 5.4 Applications of ordinary differential equations in engineering fields (*SEC. 2.9 Modeling: Electric Circuits and related numerical problem from Erwin Kreyszig Advance Engineering Mathematics 10th edition*)
- 5.5 Initial value problems.
- 5.6 Non-homogeneous Equations.
- 5.7 Solution of differential equations in series form
- 5.8 Legendre's equation (Statement only), Bessel's equation (without proof), Bessel's function (without proof) and recurrence relations.

Marks Distributions

Question Type	No. of Questions	Marks	Total Marks
Short	10	2	20
Long	10	4	40

Chapter wise marks division in final examination

SN	Chapter	Number of short questions	Number of long questions	Total
1	Analytic Geometry of 3-D	2	3	5
2	Plane Curves and Polar Coordinates	1	1	2
3	Infinite Series	2	1	3
4	Vector Calculus	1	2	3
5	Differential Equation	4	3	7
Total		10	10	20

(3)



Note:

- One long question and one short question from 1.1 to 1.2; one long and one short question from 1.3; one long with "OR" questions from 1.4 to 1.5
- One long question with "OR" and one short question from 2.1 to 2.2.
- Two short questions from 3.1 to 3.2.; one long question from 3.3
- One long question from 4.1 to 4.2.; one long question with "OR" and one short question from 4.3.
- One long question and one short question from 5.1; one short question from 5.2; two long questions with "OR" and two short questions from 5.3 to 5.8.



II SEMESTER (MODEL QUESTION)

Level: Bachelor
Program: BE Biomedical/Civil/Computer/Electronics/Electrical/Geomatic)
Semester: II

FULL MARKS:- 60

TIME:- 03:00 hrs.

PASS MARKS:- 24

Group A

Attempt all questions.

[10 x 2 = 20]

1. Find the cylindrical co-ordinates of the point having Cartesian co-ordinate (1, 0, 1).
2. Find the point where the line $\frac{x}{2} = \frac{y}{3} = \frac{z}{1}$ meets the plane $x - 2y + z = 0$.
3. Find the area of the polar curve $r^2 = 4\cos 2\theta$.
4. Test the convergence of the series $\sum \frac{1}{n^2+n}$.
5. Test the convergence of the series $\sum ne^n$ by using integral test.
6. Find the unit vector normal to the surface $z = x^2 + y^2$ at the point (1, 2, -5).
7. Solve: $(1 + x^2)dy = (1 + y^2)dx$.
8. Find the general solution of $y'' + 4y' + 4 = 0$.
9. Find particular integral of $(D^2 - 4)y = e^{-x}$.
10. Solve: $p^2 - 7p + 12 = 0$.

Group: B

Attempt all questions.

[10 x 4 = 40]

11. Find the equation of plane through the intersection of planes $x + 2y + z = 3$ and $2x - 3y + 4z = 5$ and perpendicular to the plane $x + y - z = 0$.
12. Show that the lines $\frac{x-1}{2} = \frac{y-2}{3} = \frac{z-3}{4}$ and $\frac{x-2}{3} = \frac{y-3}{4} = \frac{z-4}{5}$ are co-planar. Also find the equation of plane in which they lie.

(5)



13. Find the equation of sphere in which the circle $x^2 + y^2 + z^2 - 2x + 3y + z = 2, x - y + 2z = 0$ is a great circle.

OR

Find the equation of cone whose vertex is (α, β, γ) and the base $y^2 = 4ax, z = 0$.

14. Derive the polar equation of conic, the focus being at the pole.

OR

Find the area of the closed curve: $r = a(1 + \cos\theta)$.

15. Find the center, radius and interval of convergence of the power series $\sum \frac{(-1)^n x^n}{n(n+1)}$.

16. Prove that the necessary and sufficient condition for a vector function \vec{r} of scalar variable t to have constant magnitude is that $\vec{r} \cdot \frac{d\vec{r}}{dt} = 0$.

17. Find the value of 'n' so that the vector $r^n \vec{r}$ is solenoidal.

OR

If $\vec{r} = x\vec{i} + y\vec{j} + z\vec{k}$ and \vec{a} is a constant vector, prove that

$$\nabla \times \left(\frac{\vec{a} \times \vec{r}}{r^3} \right) = -\frac{\vec{a}}{r^3} + \frac{3(\vec{a} \cdot \vec{r})}{r^5} \vec{r}$$

18. Solve: $\frac{1}{y} \frac{dy}{dx} + 1 = xy$.

19. Solve: $(D^2 - 2D + 1)y = x^2 e^{3x}$.

20. Solve the differential equation by power series method: $y'' - y = x$.

OR

Prove the Bessel's function: $J_0'(x) = -J_1(x)$.

6



PURBANCHAL UNIVERSITY
Faculty of Engineering
Micro Syllabus (New Course)
BE Second Semester
Program: Civil/Geomatic

Subject: Physics

Teaching Schedule Hours/Week				Examination Scheme				
Cr	Theory	Tutorial	Practical	Internal Assessment		Final		Total Marks
4	4	2	2	Theory	Practical	Theory	Practical	125
				40	10	60	15	

S. N.	Topics	Lecture hours	Sub topics	Depth
1	Mechanical oscillation	5 hrs	1.1 Physical Pendulum: Interchangeability of point of suspension and oscillation, minimum and maximum time period, Torsion pendulum	Definition, derivation, Proof, explanation, example,
			1.2 Free oscillation	Definition, explanation, example
			1.3 Damped oscillations: angular frequency, critical damping, overdamping, and under damping	Definition, explanation, example
			1.4 Forced oscillation: Damped oscillation with a periodic driving force, Resonance, and its consequences	Definition, explanation, example
2	Ultrasonics	3 hrs	2.1 Introduction; Production of ultrasonics: Mechanical method (Introduction only); Piezoelectric generator; Magnetostriction oscillator	Definition, explanation, example
			2.2 Detection of ultrasonic; Applications of ultrasonics	explanation, example
			2.3 Acoustic grating: Determination of velocity of sound in a liquid	Definition, explanation, example
3	Relativity	5 hrs	3.1 Frame of reference; Inertial and non-inertial frames of references	Definition, explanation, example
			3.2 Postulates of the special theory of	explanation



			relativity	
			3.3 Lorentz transformation equations; Length contraction; Time dilation. Twin paradox	Definition, derivation, Proof, explanation, example,
			3.4 Simultaneity; Relativistic mass; Mass and energy	Definition, derivation, Proof, explanation, example,
			3.5 Space-time diagram.	explanation
4	Optics	Geometrical optics 3 hrs	4.1.1 Sign Convention (Cartesian coordinate system), Equivalent focal length of two thin lenses separated by a finite distance; Cardinal points of an optical system.	Definition, derivation, Proof, explanation, example,
			4.1.2 Chromatic aberration in a lens (longitudinal chromatic aberration), Condition for achromatism of two thin lenses in contact and separated by a finite distance	Definition, derivation, Proof, explanation, example,
		Fiber optics 3 hrs	4.2.1 Introduction; Step index optical fiber, Graded index optical fiber.	Definition, explanation, example,
			4.2.2 Self-focusing; Acceptance angle; Numerical aperture.	derivation, explanation, example,
			4.2.3 Application of optical fiber.	explanation, example,
	10 hrs	Interference	Interference: Young's double-slit experiment; Analytical treatment of interference; Fresnel's Biprism; Interference in thin-film: reflected and transmitted light; Wedge shape thin film: determination of fringe width; Newton's rings: reflected and transmitted light; determination of the wavelength of light and refractive index of the liquid.	Definition, derivation, Proof, explanation, example,
		Diffraction	Introduction: Fresnel and Fraunhofer diffraction; Fraunhofer's diffraction at a single slit; Intensity in single diffraction pattern (qualitative); Fraunhofer diffraction at double slit; Diffraction grating; Holography and Interference pattern	Definition, explanation, example
		Polarization	Malus Law, Double refraction; Nicol	Definition,



			prism Quarter wave plate; Half-wave plate; Optical activity; Specific rotation	explanation, example
5	Electrostatics	7 hrs	5.1 Electric field intensity, Electric dipole and dipole moment, Electric field intensity due to a dipole (at an axial and equatorial line), Electric quadrupole and quadrupole moment, Electric field intensity due to quadrupole (at an axial line)	Definition, derivation, Proof, explanation, example,
			5.2 Electric potential, Electric potential due to a dipole, Electric potential due to quadrupole (at an axial line)	Definition, derivation, Proof, explanation, example,
			5.3 Electric flux, Gauss's law (statement only), Application of Gauss's law; Spherical charge distribution (non-conducting and conducting)	Definition, Derivation explanation, example,
			5.4 Ink-jet printing; Volcanic lightning	Definition, explanation,
			5.5 Capacitor and capacitance, Parallel plate capacitor and Cylindrical capacitor, Supercapacitor (introduction only), Energy stored in electric field and energy density	Definition, explanation, example,
			5.6 Polar and non-polar dielectrics, Polarization, Gauss's law, and dielectrics (Relation between E, D, and P)	Definition, explanation, example,
6	Direct current	3 hrs	6.1 Electric Current; Current Density, Drift Speed	Definition, explanation, example,
			6.2 Effect of Temperature on Resistance and Resistivity; Microscopic view of Ohm's Law.	Definition, explanation, example,
			6.3 Superconductivity, Critical Magnetic field, The Meissner Effect, Types of Super conductors	Definition, explanation, example,
7.	Magnetism and Magnetic field	8 hrs	7.1 Magnetic properties of matter; Domain theory; Ferromagnetism; Saturation and hysteresis	Definition, explanation, example,
			7.2 Lorentz force; Cyclotron; Cyclotron frequency; Synchrotron; Hall effect	Definition, derivation, Proof, explanation, example,
			7.3 Current carrying coil as a magnetic	Definition,



			dipole; Magnetic field produced by a magnetic dipole	derivation, Proof, explanation, example,
			7.4 Faraday's law of electromagnetic induction; Lenz's law; Electric guitars	Definition, explanation, example,
			7.5 Self-induction; Inductance of a Solenoid; Metal detector	Definition, explanation, example,
			7.6 Eddy currents; Induction stoves	Definition, explanation, example,
			7.7 LR circuit, Energy stored in magnetic field; Energy density of magnetic field.	Definition, derivation, Proof, explanation, example,
			7.8 Induced Magnetic Field; Displacement Current	Definition, explanation, example,
8	Electromagnetic waves	5 hrs	8.1 Gauss divergence theorem and Stoke's theorem (statement only).	Definition, explanation, example,
			8.2 Maxwell's equation (integral to differential form); Equation of continuity.	Definition, derivation, explanation, example,
			8.3 Wave equation in free space and medium.	Definition, derivation, explanation, example,
			8.4 Speed of electromagnetic wave; Ratio of electric field and magnetic field.	Definition, explanation, example,
			8.5 Poynting vector	Definition, explanation, example,
9	Quantum Mechanics	5 hrs	9.1 Newtonian mechanics and Quantum mechanics	explanation, example,
			9.2 Matter wave; de-Broglie wave equation; Uncertainty Principle (qualitative); Phase velocity and group velocity; relation between phase velocity and group velocity	Definition, explanation, example,
			9.3 Wave function; Physical	Definition,



			interpretation of the wave function	explanation, example,
			9.4 Schrodinger wave equation (time-independent and time-dependent)	Definition, derivation, explanation, example,
			9.5 Applications of Schrodinger wave equation: Particle in one dimensional infinite potential well; Normalization and probability density; Potential barriers and Tunneling effect (transmission coefficient qualitative); Application of Tunneling	Definition, derivation, explanation, example,
10	Non-Destructive Testing	3 hrs	10.1 Introduction; Methods of non-destructive testing: Magnetic method; Electrical method; Radiographic method; Ultrasonic method; Thermal method	Definition, explanation, example,
			10.2 Comparisons of γ -ray radiography and X-ray radiography; Thermography	Definition, explanation, example,

Reference Books:

- Halliday, Resnick, and Walker-Fundamentals of Physics, 6th Edition, John Wiley & Sons
- Vasudeva A.S.-Modern Engineering Physics, S. Chand & Company Ltd, New Delhi
- Subrahmanyam and Brij Lal-A Text Book of Optics, S. Chand & Company Ltd, New Delhi
- B.K. Sapkota, B. Pokharel and B. K. Bhattarai, Fundamentals of Engineering Physics, Benchmark Publication, Kathmandu.
- Sears and Zemansky's-University Physics with Modern Physics, 12th Edition, Pearson Education.
- C. L. Arora-BSc Practical Physics, S. Chand & Company Ltd.
- B. K. Sapkota and B. Pokharel, Engineering Practical Physics, Benchmark Publication, Kathmandu.

S. N.	Topics	Time allocation	Marks	Types of questions		
				Very short	Short	Long
1	Mechanical oscillation/relativity	10 hrs	14	1	1	1
2	Ultrasonics	3 hrs	4		1	
3	Geometrical Optics/Physical Optics	13 hrs	18	1	1 or 1	1
4	Fiber optics	3 hrs	4		1	
5	Electrostatics/ Direct current	10 hrs	14	1	1	1
6	Magnetism and Magnetic field/	13 hrs	14	1	1	1



	Electromagnetic waves					
7	Quantum Mechanics	5 hrs	6	1	1	
8	Non-Destructive Testing	3 hrs	4		1	
	Total	60 hrs	60/78	4/5	7/9	3/4

There will be 4 questions in very short type, carrying 2 marks each. There must be at least 2 theoretical questions and 2 compulsory numerical.

There will be 7 questions in short type, carrying 4 marks each. There must be at least 2 theoretical questions and 5 compulsory numerical.

There will be 3 questions in long type carrying 8 marks each. There may be some breakdown in this type of question. All questions can be of derivation/analysis/explanatory type.

Recommendation: The credit hours allocated seems to be 3 which is insufficient with the depth of the course. Therefore, this workshop recommends the university to allocate 4 credit hours for the prescribed curriculum so that the objective mentioned will be fulfilled.



Purbanchal University

Model Question - I

Time: 03 hrs.

BE --- SH: Physics (New Course) Semester: II

B.E. Civil/ Geomatic

Full Marks: 60

Pass Marks: 24

Candidates are required to give their answers in their own words as far as practicable.

The figures in the margin indicate full marks

Answer ALL questions.

Group A (4 2 = 8)

1. Is it possible to have damped oscillation when a system is at resonance? Explain. (2)
2. If the plane of polarization of a given solution is turned through 6.6° , calculate the specific rotation of the sample. The length of 20% solution is 10 cm. (2)
3. In parallel plate capacitor the capacitance increase from $4 \mu\text{F}$ to $80 \mu\text{F}$ on introduction dielectric medium between the plates. What is the dielectric constant of the medium? (2)
4. Discuss in brief the similarities between the energy stored in the electric field of a charged capacitor and energy stored in the magnetic field of a current -carrying coil. (2)

Or

If matter has a wave nature, why is this wave-like characteristic not observable in our daily experiences? (2)

Group B (7×4=28)

5. Discuss the principal of producing ultrasonics by Piezo-electric method. (4)
6. Define acceptance angle. Show that acceptance angle, where n_1 and n_2 are the refractive index of the core and cladding. (1+3)

Or

How X-ray radiography differ from γ -ray radiography. Illustrate your answer with important of each technique. (4)

7. A thin converging lens and a thin diverging lens are placed co-axially at a distance 5 cm. If the focal length of each lens is 10 cm, find for the combination (i) focal length (ii) power (iii) positions of the principal points. (1+1+2)

Or

Calculate the first and second-order angles for the light of wavelength 400 nm, if the grating contains 10,000 lines/cm.

8. A certain process requires 10^{-4} sec to occur in an atom at rest in the laboratory. How much time will this process require to an observer in the laboratory when the atom is moving with a speed of 5×10^7 m/s. (4)
9. What is the drift speed of the conduction electrons in a copper wire with radius r when it has a uniform current I ? Assume that each copper atom contributes one conduction electron to the current and the current density is uniform across the wire's cross section. (4)
10. A radio station on the surface of the earth radiates a sinusoidal waves with an average total power of 50 Kw. Assuming that the transmitter equally in all directions above the ground (which is unlikely in real situations), find the amplitudes and detected by a satellite at a distance 100 km from the antenna. (4)

(13)



11. A beam of electrons having the energy of each 3 eV is incident on a potential barrier of height 4 eV. If the width of the barrier is 20 Å. Calculate the percentage transmission of the beam through the barrier. (4)

Group C (8 3 = 24)

12. Point out the similarities and dissimilarities between the oscillations of the physical pendulum and torsional pendulum. Derive an expression for the time period and modulus of the rigidity of the suspension wire in case of the torsional pendulum. (2+3+3)
13. Give the theory of wedge shaped thin film for determining the fringe width. (8)
14. What is a quadrupole moment? Is it vector quantity? Derive an expression for electric field intensity due to quadrupole at a point on the axial line. Draw the graphical representation of electric field intensity E with axial distance r from mid-point. (1+1+5+1)

Or

What is Hall effect? Derive an expression for the Hall coefficient and establish a relation between the mobility of the charge carrier and the conductivity of the metallic conductor. Elaborate on quantized Hall Effect. (1+5+2)

(14)



Purbanchal University
Model Question - II

Time: 03 hrs.

BEG SH: Physics (New Course)

Semester-II

Full Marks: 60

Pass Marks: 24

Program: Civil/Geomatic

Candidates are required to give their answers in their own words as far as practicable.

The figures in the margin indicate full marks

Answer ALL questions.

Group A (4 × 2 = 8)

1. Is there any real difference between a polarizer and an analyzer? In other words, can a polarizer be used as an analyzer, and vice versa? (2)
2. Why does a dipole produce an electric field at all? After all, the dipole has no net charge. (2)

OR

List some similarities and difference between inductors and capacitors. (2)

3. Calculate the thickness of a quarter-wave plate. (Given that, $\mu_r = 1.5334$, $\mu_o = 1.544$ and $\lambda = 5000$ Å)
4. What is the de Broglie wavelength of a 15 kV proton of mass 1.67×10^{-27} kg?

Group B (7×4=28)

5. The amplitude of a lightly damped oscillator decreases by 3.0 % during each cycle. What fraction of the mechanical energy of the oscillator is lost in each full oscillation. (4)
6. Discuss in brief various methods for detecting ultrasonic. (4)

OR

What are γ -ray radiography and X-ray radiography? Explain. (2+2)

7. A glass-cladding fiber is made with the core glass of a refractive index of 1.5 and the cladding is doped to give a fractional index change of 0.0005. Calculate: (a) the R.I. of the cladding (b) the acceptance angle, and (c) the numerical aperture. (1.5+1.5+1)
8. Two thin lenses (same material) of focal length f_1 and f_2 separated by a certain distance d have an equivalent focal length of 50 cm. The combination satisfies the condition for no chromatic aberration and minimum spherical aberration. Find the values of f_1 , f_2 , and d . (1.5+1.5+1)

OR

A plane transmission grating having 600 lines/cm is used to obtain a spectrum of light from a sodium lamp in the second order. Calculate the angular separation between the two sodium lines whose wavelengths are 5890 Å and 5896 Å. (4)

9. A conductor of uniform radius 1.2 cm carries a current of 3 A due to the potential gradient of 120 V/m. What are the value of current density and specific resistance of the materials? (2+2)
10. A copper strip 150 m thick is placed in a magnetic field of strength 0.65 T perpendicular to the plane of the strip and a current of 23 A is set up in the strip. Calculate: (a) the Hall voltage, (b) the Hall coefficient, and (c) Hall mobility. (Given, number of electrons per unit volume = $8.5 \times 10^{28} \text{ m}^{-3}$ and resistivity = $1.72 \times 10^{-8} \text{ ohm-m}$) (1.5+1.5+1)
11. What is the significance of the wave function? Derive the time-independent Schrodinger wave. (1+3)

(15)



Group C (3 × 8 = 24)

12. (a) Write down the basic postulates of the special theory of relativity. (4)
- (b) Derive the Lorentz space-time transformation formulae. Also, discuss time dilation and length contraction. (4)
13. For interference in thin film show that the film which appears bright in reflected light appear dark in transmitted light. (4+4)
14. A current carrying coil behaves as magnetic dipole. What magnetic field does the magnetic dipole produce at a point in the surrounding space. (8)

OR

Write Maxwell's equations in integral form and convert them into differential form. (2+6)

◆◆◆



Purbanchal University
Model Question - III

Time: 03 hrs.

BEG SH: Physics (New Course)

Semester-II

Full Marks: 60

Pass Marks: 24

Program: Civil/ Geomatic

Candidates are required to give their answers in their own words as far as practicable.
The figures in the margin indicate full marks

Answer ALL questions.

Group A (4 2 = 8)

1. Why is critical damping desirable in a car's suspension system? (2)
2. Suppose that the electric field of an electromagnetic wave decreases in magnitude. Does the magnetic field increase, decrease or remains the same? Account for your answer. (2)

OR

A capacitor is said to carry a charge Q . What's the net charge on the entire capacitor?
(1+1)

3. To make a quarter-wave plate of calcite for the light of wavelength 589 nm, how thick it should be? (Given, $\mu_o = 1.658$; $\mu_e = 1.486$) (2)
4. A beam of aluminum atoms is used to dope a semiconductor chip to set its electrical properties. If atom's velocity is known to within 0.2 m/s, how accurately can they be positioned? (2)

Group B (7 4 = 28)

5. A rod 1 m long is moving along its length with a velocity of 0.6 c . Calculate its length as it appears to an observer. (1.5+1.5+1)
 - (a) On the earth
 - (b) Moving with the rod itself
 - (c) Calculate the percentage of contraction.
6. In a proton accelerator used in elementary particle physics experiments, the trajectories of protons are controlled by bendings magnets that produce a magnetic field of 6.6 T. What is the energy density in this field in the vacuum between the poles of such magnet? (4)
7. Two thin lenses having the power 5 D and 4 D are placed at a distance of 10 cm apart. Calculate the power of the equivalent lens of these two lenses. (4)

OR

- How many orders will be visible if the wavelength of the incident radiation is 5000 Å and the number of the lines on the grating is 2620 in one inch? (4)
8. Assume that an electron is moving along an x axis and that you measure its speed to be v , which can be known with a precision of Δv . What is the minimum uncertainty with which you can simultaneously measure the position of the electron along the x axis? (4)
 9. An observer is 1.8 m from an isotropic point light source whose power is 250 W. Calculate the rms values of the electric and magnetic fields due to the source at the position of the observer. (2+2)



10. What is acoustic grating? Explain how an acoustic grating is used to determine the velocity of ultrasonic waves in liquids. (1+3)
11. What is the importance of non-destructive tests? How X-ray radiography differs from γ -ray radiography? (2+2)

OR

Explain the mechanism of light propagation in optical fiber. Discuss in brief different types of optical fibers. (2+2)

Group C (8 3 = 24)

12. What is free oscillation? Derive an expression for the time period of a physical pendulum. Show that point of oscillation and the point of suspension are interchangeable. (1+4+3)

OR

Discuss the necessary theory in determining the wavelength of light using Fresnel Biprism. (8)

13. State Gauss's law and use it to find an electric field at a point inside and outside the uniformly charged insulating sphere. (4+4)
14. Discuss in brief the principle operation of the cyclotron. Derive an expression for the maximum kinetic energy achieved by a particle and mass m in terms of the applied magnetic field and the radius. (3+5)

(18)

Year: I				Semester: II				
Teaching Hours/week				Examination Scheme				Total Marks
				Internal		Final		
Cr	L	T	P	Theory	Practical	Duration	Marks	
3	3	3	-	40	-	60	100	

Course Objective:

The purpose of the course is to provide basic knowledge of engineering mechanics dynamics portion to the students such that they can understand the basics of kinematics and kinetics for both particles and rigid bodies and their motion.

Detailed Course Contents:

Ch No.	Topic	Subtopic	Depth						Hour	Remarks		
			SD	D	DR	I	E	A			EX	N
1	Introduction	1.1	✓							1		
2	Rectilinear Motion of Particles	1.1	Definition, branches, importance of dynamics									
		2.1	Position, velocity and acceleration	✓							✓	
		2.2	Determination of motion of particles		✓						✓	
		2.3	Uniform rectilinear motion		✓						✓	
		2.4	Uniformly accelerated rectilinear motion		✓						✓	
2.5	Motion of several particles		✓						✓			

(10)



		Graphical solution of rectilinear motion problems																			
3	Curvilinear Motion of Particles	2.6																			
		3.1	Position vector, velocity and acceleration																		
		3.2	Derivative of vector function																		
		3.3	Rectangular components of velocity and acceleration																		
		3.4	Motion relative to a frame in translation																		
		3.5	Tangential and normal components of velocity and acceleration																		
4	Kinetics of particles: Newton's Second law	3.6	Radial and transverse components of velocity and acceleration																		
		4.1	Newton's second law of motion																		
		4.2	Linear momentum and rate of change																		
		4.3	System of units																		
		4.4	Equations of motion and dynamic equilibrium																		
		4.5	Angular momentum and rate of change																		
		4.6	Equations of motion-radial and transverse components																		



		Motion due to a central force-conservation of momentum																					
5	Kinetics of Particles: Energy and Momentum Methods	4.7	Newton's law of gravitation																				
		4.8	Applications to space mechanics																				
		4.9	Work done by a force																				
		5.1	Kinetic energy of a particle																				
		5.2	Principles of work and energy: application																				
		5.3	Power and efficiency																				
		5.4	Potential energy																				
		5.5	Conservation of energy																				
		5.6	Principle of impulse and momentum																				
6	Kinematics of Rigid Bodies	5.7	Impulsive motion and impact																				
		5.8	Direct central impact																				
		5.9	Oblique impact																				
		6	Introduction to system of particles																				
		6.1	Introduction																				
		6.2	Translation																				
		6.3	Rotation																				
		6.4	General plane motion																				



6.5 6.6 6.7 6.8 6.9 6.10 6.11 7.1 7.2 7.3 7.4	Absolute and relative velocity in plane motion	✓					
	Instantaneous center of rotation	✓	✓				✓
	Absolute and relative Frame; Coriolis acceleration in plane motion	✓		✓			
	Rate of change of a general vector with respect to a rotating Frame; Coriolis acceleration	✓					
	Motion about a fixed point	✓	✓				
	General motion	✓	✓				✓
	Three dimensional motion of a particle relative to a rotating frame: Coriolis Acceleration	✓					
	Equations of motion for a rigid body	✓				✓	
	Angular momentum for a rigid body in plane motion	✓				✓	
	Plane motion of a rigid body; D. Alembert's principle	✓				✓	✓
	Application of rigid body motion in the plane						✓
7	Plane Motion of Rigid Bodies; Forces, Moments and Accelerations						6



8	Plane Motion in Rigid Bodies: Energy and Momentum methods	7.5	Constrained motion in the plane	✓																	
		8.1	Principles of work and energy for a rigid Body	✓																	
		8.2	Work done by external forces	✓																	
		8.3	Kinetic energy for a system	✓																	
		8.4	Conservative and non-conservative system	✓																	
		8.5	Works-energy applications																		
		8.6	Impulse and momentum for systems of rigid bodies																		
		8.7	Conservation of angular and linear momentum																		
		8.8	Impulsive motion and eccentric impact																		
		9	Vibrations	9.1	Undamped free vibrations of particles and rigid bodies: simple harmonic motion, frequency and period of oscillation																
9.2	Steady harmonic forcing of undamped systems																				
9.3	Introduction to structural vibration			✓																	

Note: Define (SD), Description (D), Derive (D), Illustration (I), Explanation (E), Application (A), Explanation (Ex), Numerical (N)

(23)

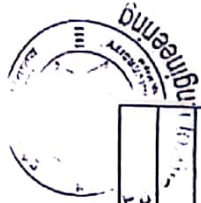

Final Examination Scheme:

Chapters	Marks	Remarks
1	1	Th
2	4	Th/N
3	5	Th/N
4	10	Th+N
5	10	Th+N
6	8	Th+N
7	8	Th + N
8	8	Th + N
9	6	Th + N
Total	60	

*Note: There might be minor deviation-in mark distribution.
Mandatory: Marks should be evaluated based on solving steps.*

References:

1. Beer F.P., & Johnston, E.R. (1987). *Mechanics for Engineers-Statics and Dynamics*. 4th edition, Mcgraw-Hill
2. Chopra, A.K. (2017). *Dynamics of Structures-Theory and Applications to Earthquake Engineering*. 5th edition. Pearson Education
3. Hibbeler, R.C, & Gupta, A. (2009). *Engineering Mechanics-Statics and Dynamics*. 11th edition. Pearson Education
4. Shames, I.H. (1990). *Engineering Mechanics-Statics and Dynamics*. 3rd edition. Prentice Hall of India.

24

between block A and the inclined plane as 0.3, determine the acceleration of each block and tension in each cord. [6]

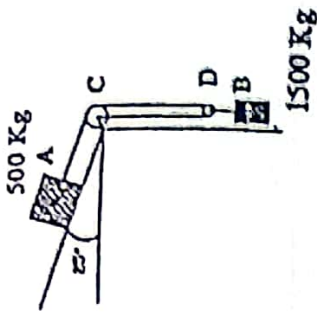

Attempt all questions

1.
 - a. Define the types of dynamics. [1]
 - b. Derive an expression for acceleration as function of position. [4]

OR

- Ball 'A' is released from rest at a height of 20m. After 1 second, a second ball 'B' is thrown upward from the ground. If the two balls pass one another at a height of 6m, Determine
- i. Speed at which the ball B was thrown upward. [4]
 - ii. Speed of each ball when they pass. [4]
- c. Derive the expression for velocity and acceleration of a particle in tangential and normal component system when the particle is moving along a curvilinear path. [5]

2.
 - a. Prove angular momentum gets conserved when particle moves under central force. [4]
 - b. The two blocks shown in fig below starts from rest. The pulleys are frictionless and the pulley is assumed to have negligible mass. Assuming the kinetic friction coefficient

3.

- a. Illustrate principle of conservation of energy of a particle with an appropriate example. [3]
- b. The initial velocities and their directions of the balls are as shown in figure. Determine the final velocities and the direction after impact. Take $e = 0.8$. Mass of ball A = 600g, mass of Ball B = 1 Kg. [7]

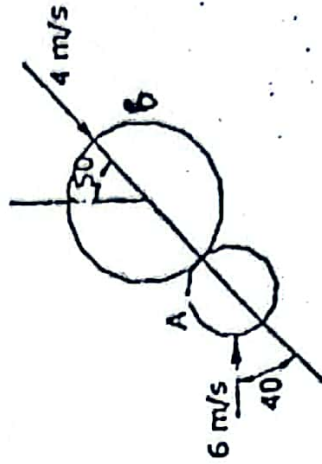

2. Define general plane motion with example. [2]
3. The double gear shown rolls on the stationary lower rack; the velocity of its center A is 1.2 m/s directed to the right. Determine: [6]

- The angular velocity of the gear,
- The velocities of the upper rack R and of point D of the gear.

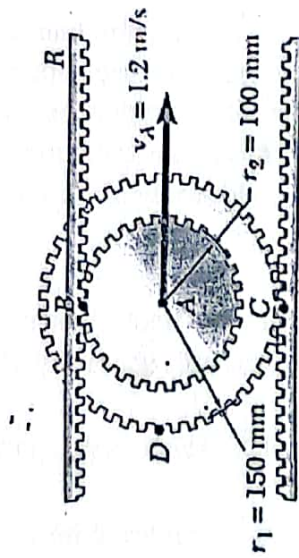

(26)

4. What are the applications of rigid body motion in plane? [2]
5. A pulley weighing 12 lb and having a radius of gyration of 8 in. is connected to two blocks as shown. Assuming no axle friction, determine the angular acceleration of the pulley and the acceleration of each block. [6]

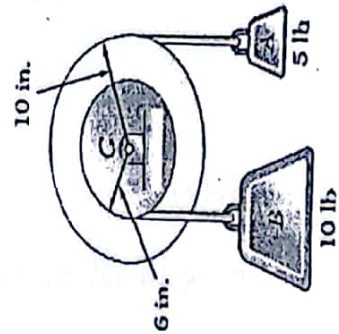

6.

- What do you mean by conservative and non-conservative system of forces. [2]
- A 30-lb slender rod AB is 5 ft long and is pivoted about a point O which is 1 ft from end B. The other end is pressed against a spring of constant $k = 1800$ lb/in. until the spring is compressed 1 in. The rod is then in a horizontal position. If the rod is released from this position, determine its angular velocity and the reaction at the pivot O as the rod passes through a vertical position. [6]

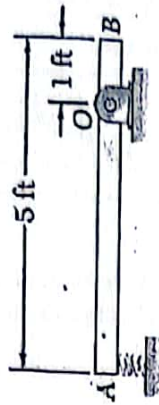

7. Derive an expression to find response of an undamped forced vibration system. [6]

BUILDING TECHNOLOGY
BE - CI



Year: I

Subject: Building Technology

Semester: II

Teaching Hours/week					Examination Scheme						Total Marks
					Internal		Final				
Cr	L	T	P	Theory	Practical	Theory		Practical			
						Duration	Marks	Duration	Marks		
3	3	1	-	40	-	3	60	-	-	100	

Course Objectives:

The basic objective of the course is to provide an essential knowledge on the functional requirement of the building components and its construction details

Course Contents:

1.0 Functional Requirements of Building

(8 hrs)

- 1.1 Moisture and its movement through building components
- 1.2 Condensation and its reasons
- 1.3 Effects if moisture and condensation on building components and materials
- 1.4 The use of vapor barriers and other damp-proof courses in building
- 1.5 Thermal properties on building components and materials
- 1.6 Thermal insulation: thermal resistance and thermal capacity
- 1.7 Sound and Acoustics: Sound and Acoustics (sound and noise, acoustic defects, sound insulation)
- 1.8 Lighting: Daylight natural and artificial
- 1.9 Energy conches design: renewable and non-renewable source of energy, active and passive methods of solar cooling and heating

2.0 Foundations

(5 hrs)

- 2.1 Foundation and its types
- 2.2 Soil exploration and method to improve bearing capacity of soil
- 2.3 Some common problems with existing foundations
- 2.4 Retaining properties and waterproofing of basements
- 2.5 Sealing of cracks in basements

3.0 Roofs

(3 hrs)

- 3.1 Single timber roofs: their types and construction details
- 3.2 Double and triple roofs: situations for their use, their elements and construction details
- 3.3 Roof coverings; tiles, slates, CGI sheets etc.

4.0 Staircases, Lift and Escalator

(3 hrs)

- 4.1 Elements of staircase
- 4.2 Essential requirements & Types of staircases
- 4.3 Relationship between rise and tread of a stair
- 4.4 Ladders, ramps, Lifts and Escalators (*General Introduction only*)



- 5.0 Doors and Windows** (3 hrs)
- 5.1 Doors parts: frame, shutter and their details (*Based on shutter and operation*)
 - 5.2 Windows: types and details (*Based on shutter and operation*)
 - 5.3 Ventilators types and details (*Introduction only*)
- 6.0 Joints** (4 hrs)
- 6.1 Types of joints: construction and expansion joints
 - 6.2 The need for provision of joints
 - 6.3 Treatment and detailing of joints at the roof levels
 - 6.4 Treatment and detailing of joints at the floor levels
 - 6.5 Treatment of joints in external walls
- 7.0 Temporary Construction** (4 hrs)
- 7.1 Scaffolding: single and double scaffolds
 - 7.2 Formwork for excavations and trenches
 - 7.3 Formworks for reinforced concrete construction
 - 7.4 Shoring: horizontal, slant and vertical shores
 - 7.5 Underpinning and its procedure
- 8.0 Cladding and External Finishing** (4 hrs)
- 8.1 Load bearing and non-load bearing cladding
 - 8.2 Brick facing
 - 8.3 Cladding in stone
 - 8.4 Cladding in concrete panels and their construction details
 - 8.5 Plastering
 - 8.6 Pointing
- 9.0 Internal Finishing** (2 hrs)
- 9.1 Non-load bearing partitions: types, functions and methods of connection to the Surrounding structure
 - 9.2 Suspended Ceilings: types, functions and methods of construction
- 10.0 Electrical Services** (2 hrs)
- 10.1 Residential and commercial requirements
 - 10.2 General principles
 - 10.3 Wiring systems
 - 10.4 Trunkings, busbars and ducts for electrical distribution (*General Introduction*)
 - 10.5 Safety precautions
- 11.0 Causes and Prevention of Cracks in Buildings** (2 hrs)
- 11.1 Cracks in different components of buildings (Walls, roofs, floors, plasters, windows, RCC, joints)
 - 11.2 Causes of cracks and remedial measures to cracks

(28)



- 12.0 Other miscellaneous services in buildings
- 12.1 CCTV, Telecommunication
 - 12.2 Air Conditioning
 - 12.3 Fire Protection
 - 12.4 General principles of water supply and sanitation system
 - 12.5 Hot Water Supply
 - 12.6 Rainwater pipes and gutters

Field Visit: One day field visit to any building construction site

Final Examination Scheme:

Chapters	Types	Remarks
1	Long, Short, Very Short	
2	Long, Short	
3	Long, Very Short	
4	Long, Short	
5	Short, Very Short	
6	Short, Very Short	
7	Long, Short	
8	Short, Very Short	
9	Short, Very Short	
10	Short, Very Short	
11	Short, Very Short	
12	Short, Very Short	
Total	60	

Question Division

no	Question Type	Marks	Number	Total
	Long Question	8	3	24
	Short Question	4	7	28
	Very Short Question	2	4	8
	Total			60

References:

1. Ching, F.D (2014), "Building Construction Illustrated" 5 th edition John Wiley & Sons.
2. Goyal M.M,(2004) "Handbook of Building Construction: The essential source of standard construction practices," Thomas Press , Reid, E.,
3. Olin H.B. (1994), "Construction Principles , Methods and Materials " 6th Edition Wiley
4. Reid, E.(1998), "Understanding Buildings" , MIT Press

(29)

PURBANCHAL UNIVERSITY
II SEMESTER MODEL QUESTION, 2022

PROGRAM:- B.E Civil (I/II)
SUBJECT:- [BE----- CI] Building Technology
TIME:- 3:00 hrs.

FULL MARKS:- 60
PASS MARKS:- 24

Candidates are required to give their answers in their own words as far as practicable. Figures in the margin indicate full marks.

Model Questions:

Very short:

Any four [2x4=8]

- What do you understand by damp proofing in a building (Ch-1) [2]
- What are the factors that causes foundation failure? (Ch-2) [2]
- Define the components of typical doors? (Ch-5) [2]
- What are the types of joint? (Ch-6) [2]
- What are the objectives of plastering? (Ch-8) [2]
- What are the objectives of air conditioning? (Ch-12) [2]

Short Question

[4x7=28]

- Write about the types of shallow foundation with neat sketch. (Ch-2) [4]
 - What are the points to be considered while locating doors and windows? (Ch-5) [4]
 - Explain the treatment procedure for expansion joints in wall with fig. (Ch-6) [4]
 - Describe how do you provide formwork for rectangular column with neat sketch. (Ch-7) [4]
- or
- What are the requirements of good staircase? (Ch-4) [4]
 - Write short notes on cladding in stone. (Ch-8) [4]
- or
- Explain brick partitions and timber partition wall. (Ch-9) [4]
 - What are the general principles of electrical services? (Ch-10) [4]
 - What are the Causes of cracks and remedial measures to cracks. (Ch-11) [4]

Long Question

[8x3=24]

- What do you mean by renewable and non-renewable source of energy? What are the effects of moisture on building components? (Ch-1) [8]

Or,

From the given wall calculate thermal transmittance (U-value). [8]

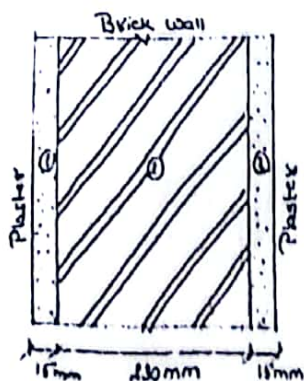

$$k_1 = 81.8 \frac{\text{k cal cm}}{\text{m}^2 \text{ h deg C}}$$

$$k_2 = 69.7 \frac{\text{k cal cm}}{\text{m}^2 \text{ h deg C}}$$

$$k_3 = 81.8 \frac{\text{k cal cm}}{\text{m}^2 \text{ h deg C}}$$

$$\text{outer conductance} = 0.0515 \frac{\text{k cal}}{\text{m}^2 \text{ h deg C}}$$

$$\text{inner conductance} = 0.125 \frac{\text{k cal}}{\text{m}^2 \text{ h deg C}}$$

- Explain four types of single roofs with figure. Draw a figure showing basic element of pitched roof. (Ch-3) [5+3]

or

What is scaffolding? Describe the types of scaffolding with neat sketches. (Ch-7) [8]

- c. Design a dog-legged staircase for a building in which the vertical distance between the floors is 3.6m. The stair hall measures 2.5m * 5m. Assume necessary data. Draw neat and clean sketch as per design. (Ch-4) [8]



As per the Model Question

Chapters	No of Long questions [8x3]	No of Short questions [4x7]	No of Very short questions [2x4]	Marks	Remarks
1	1		1	10	
2	1	1		12	
3	1		1	10	
4	or	1		4	
5		1	1	6	
6		1	1	6	
7	or	1		4	
8		1	or	4	
9		1	or	4	
10		or	or		
11		or	or		
12		or	or		
Total	5	10	9	60	

(21)



Fundamentals of Thermodynamics and Heat transfer

Year: I

Semester: II

Teaching Hours/week				Examination Scheme						Total Marks
				Internal		Final				
				Theory	Practical	Theory		Practical		
Cr	L	T	P			Duration (in hrs)	Marks	Duration	Marks	
2	2	1	2/2	20	25	1.5	30			75

Course Objectives:

To provide the students with a basic understanding and norms of Thermodynamics and Heat Transfer

Course Content:

1. Basic Concepts (3 hours)
 - 1.1. Definition and Application areas of Thermodynamics
 - 1.2. Concepts and Definitions
 - 1.2.1. System, Surroundings, Boundary and Universe
 - 1.2.2. Thermodynamic Properties: Intensive, Extensive and Specific Properties
 - 1.2.3. Thermodynamic State and equilibrium and quasi-static process
 - 1.2.4. Thermodynamic Processes and Cycles: Isobaric, isothermal and isochoric processes
Cyclic Process, Quasi-equilibrium Process, Reversible and Irreversible Process
 - 1.3. Common Properties: Pressure, Specific Volume, Temperature
 - 1.4. Zeroth Law of Thermodynamics, Equality of Temperature
 - 1.5. Value of energy to society
2. Energy and Energy Transfer (4 hours)
 - 2.1. Energy and its Meaning
 - 2.2. Stored Energy and Transient Energy; Total Energy
 - 2.3. Energy Transfer as heat and work
 - 2.4. Expressions for displacement work transfer (*Isobaric work, Isochoric Work, Isothermal and Polytropic work*)
 - 2.5. Power

(21)



3. **Properties of Common Substances (4 hours)**
 - 3.1. Ideal Gas (*Boyles Law, Charles Law*) and *Combined Gas Equation*
 - 3.2. Saturation curves For Two- Phase Mixture (T-v and P-v) Diagrams
 - 3.3. Two Phase (Liquid and Vapor) Systems: Phase Change; Subcooled Liquid, Saturated Liquid, Wet Mixture, Critical Point, Quality, Moisture Content, Saturated Vapor and Superheated Vapor
 - 3.4. Other Thermodynamic Properties: Internal Energy, Enthalpy, *Specific heat Capacities*
 - 3.5. *Numerical related to Steam Table (Specific Propertles related to quality)*

4. **First Law of Thermodynamics (6 hours)**
 - 4.1. Introduction and law of conservation of energy
 - 4.2. First Law of Thermodynamics for closed systems; First Law of Thermodynamics for closed system Undergoing Cyclic Process
 - 4.3. Application of the First law of Thermodynamics to Closed systems undergoing some common process: Constant Volume, Adiabatic, Constant Pressure, Constant Internal Energy.
 - 4.4. First Law of Thermodynamics for open systems (Control Volume)
 - 4.4.1. Conservation of mass, expression of mass flow rate, flow work and general energy equations
 - 4.4.2. Steady State Analysis and applications
 - 4.5. Other Statements of the First Law
 - 4.6. Perpetual Motion Machine of the kind PMM I

5. **Second Law of Thermodynamics (7 hours)**
 - 5.1. Necessity of Formulation of Second Law
 - 5.2. Kelvin-Planck and Clausius Statements of the Second Law of Thermodynamics
 - 5.3. Heat Engine and Thermal Efficiency, Heat Pump, Refrigerator and coefficient of Performance (COP) (*Theory and Numerical*)
 - 5.4. Entropy and entropy change (*introduction and definition*)
 - 5.5. Reversible and Irreversible Process
 - 5.6. Entropy and Process Relation for an Ideal Gases
 - 5.7. Isentropic Process for an Ideal Gas
 - 5.8. Air Standard Otto Cycle and Diesel Cycle (*Theory and Numerical*)

6. **Introduction to Englnering Heat Transfer:(6 hours)**
 - 6.1. Basic concepts and modes of heat transfer
 - 6.2. One Dimensional Steady State Heat Conduction through a Plane Wall/Flat Plate
 - 6.3. Radial Steady State Heat Conduction through a Hollow Cylinder
 - 6.4. Heat Flow through Composite Structures
 - a. One Dimensional Steady State Heat Conduction through a Composite Wall
 - b. Radial Steady State Heat Conduction through a Multilayer Tube
 - 6.5. *Overall heat transfer for Plane composite wall*
 - 6.6. Electrical Analogy for Thermal Resistance

(2)



Laboratories:

- Temperature measurement
- Experiment related to heat pump or refrigerator
- Experiment related to heat transfer conduction, radiation and Convection

Tutorials:

- a) Three assignments in each before first and second assessments.
- b) Quiz before first and second assessments.

Final Examination Scheme:

Chapters	Marks*	Remarks
1	2	
2	4	
3 and 4	7	
5	9	
6	8	
Total	30	

There may be minor deviation in marks distribution.

References: (in APA style)

1. C.P., G., & R., P. (1991). *Engineering Thermodynamics*. Roorkee: Nemchand & Broj.
2. Cengel, Y. A., Boles, M. A., & Kanoglu, M. (2019). *Thermodynamics: An Engineering Approach*. McGraw-Hill Education.
3. Howell, J. R., & Bucckius, R. O. (1987). *Fundamental of Engineering Thermodynamics*. Mc Graw Hill Publishers.
4. P.K., N. (n.d.). *Engineering Thermodynamics*. New Delhi; Tata Mc Graw Hill.



PURBANCHAL UNIVERSITY (M.B.A. Question)

2022

B.E.(Civil)/ Second Semester/Final
Sub: BEG.....ME

F.M=30

P.M=12

Time: 1.5hr

Fundamental of Thermodynamics and Heat transfer

Candidates are required to give their answers in their own words as far as practicable.

The figures in the margin indicates full marks.

Answer ALL questions

1. Define thermodynamics system, surrounding, boundary and reversible process. 2
2. Define saturation temperature, critical point and superheated vapour. 2
3. What do you mean by work transfer? Derive an expression to calculate work transfer during isothermal process. 4
4. Explain an air standard otto cycle on P-V and T-S diagram 4
5. Establish the relation to calculate the overall heat transfer coefficient of a composite wall. 4
6. An exterior wall of a house may be approximated by a 10cm layer of common brick ($k=0.7\text{W/m}^{\circ}\text{C}$) followed by a layer of a 3.8cm of a cement plaster ($k=0.48\text{W/m}^{\circ}\text{C}$). What thickness of loosely packed rock-wool insulation ($k=0.065\text{W/m}^{\circ}\text{C}$) should be added to reduce the heat loss (or gain) through the wall by 80 percent? 4
7. 5 kg of H_2O is contained in a closed rigid container with as initial pressure and quality of 1000 kPa and 40% respectively. Heat is added to the system until the container holds only saturated vapour. Sketch the process on P-v and T-v diagram and determine: (Refer to steam table)
 - the volume of the container, and
 - the final temperature 5
8. At the beginning of the compression process of an air standard Diesel cycle operating with a compression ratio of 18, the temperature is 300K and the pressure is 0.1MPa. The cutoff ratio for the cycle is 2. Determine
 - The temperatures and the pressure at the end of each process of the cycle.
 - The thermal efficiency 5

Properties of Saturated water- pressure table

P kPa	T $^{\circ}\text{C}$	v_f m^3/kg	v_{fg} m^3/kg	v_g m^3/kg	h_f kJ/kg	h_{fg} kJ/kg	h_g kJ/kg
100	99.632	0.001043	1.6933	1.6943	417.51	2257.6	2675.1
1000	179.92	0.001127	0.1933	0.1944	762.88	2014.8	2777.7
2500	223.99	0.001197	0.07875	0.07995	961.97	1840.2	2802.2
2750	229.11	0.001207	0.07151	0.07272	985.85	1817.2	2803.0

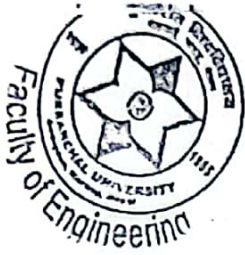

Properties of superheated steam

P kPa	T °C	v m ³ /kg	u kJ/kg	h kJ/kg	s kJ/kg.K
400	(143.64)	(0.4625)	(2553.5)	(2738.5)	(6.8961)
	150	0.4708	2564.4	2752.8	6.9300
	200	0.5342	2646.4	2860.1	7.1699
	250	0.5951	2725.6	2963.6	7.3779
	300	0.6548	2804.4	3066.3	7.5654
	350	0.7139	2883.8	3169.4	7.7378
	400	0.7726	2964.3	3273.3	7.8982
	450	0.8311	3046.0	3378.5	8.0489
	500	0.8894	3129.3	3485.0	8.1914



Year: I

Semester: II

Teaching Hours/ Week				Examination Scheme						Total Marks
				Internal		Final				
Cr	L	P	T	Theory	Practical	Theory		Practical		
						Duration	Marks	Duration	Marks	
3	1	3	-		60	-	-	3 Hrs.	40	100

Course Objectives:

To develop a good understanding of isometric and orthographic projection drawings, assembly & disassembly drawing of machine components and other basic engineering drawings in civil, electronic, electrical and geographical. To develop sketching and drafting skills to facilitate communication.

Course Contents:

1. **Pictorial Drawings** (14 Hrs)
 - 1.1. Introduction: Character, advantage and disadvantages.
 - 1.2. Axonometric Projection: Isometric drawing
 - 1.3. Oblique Drawing
 - 1.4. Perspective projection: Parallel and Angular Perspective

2. **Familiarization with Different Components and Conventions** (10 Hrs)
 - 2.1. Limit Dimensioning and Machining Symbols
 - 2.1.1. Limit, Fit and Tolerances
 - 2.1.2. Machining Symbols and Surface Finish
 - 2.2. Threads, Bolts and Nuts
 - 2.2.1. Thread Terms and Nomenclature, Forms of Screw Threads
 - 2.2.2. Detailed and Simplified Representation of Internal and External Threads
 - 2.2.3. Thread Dimensioning
 - 2.2.4. Standard Bolts and Nuts: Hexagonal Head and Square Head
 - 2.2.5. Conventional Symbols for Bolts and Nuts
 - 2.3. Welding and Riveting
 - 2.3.1. Types of Welded Joints and Types of Welds, Welding Symbols
 - 2.3.2. Forms and Proportions for Rivet Heads, Rivet Symbols, Types of Riveted Joints: Lap Joint, Butt Joint
 - 2.4. Familiarization with Graphical Symbols and Conventions in Different Engineering Fields
 - 2.4.1. Standard Symbols for Civil, Structural and Agricultural Components
 - 2.4.2. Standard Symbols for Electrical, Mechanical and Industrial Components
 - 2.4.3. Standard Symbols for Electronics, Communication and Computer Components



- 2.4.4. Topographical Symbols
 2.5. Standard Piping Symbols and Piping

3. **Design and Production Drawing- Machine Drawing** (16 Hrs)
 3.1. Introduction: Production of complete design and assembly drawings
 3.2. Fundamental Techniques: Size and location dimensioning
 3.3. Placement of dimension lines and general procedures
 3.4. Standard dimensioning practice (SI system)
 3.5. Drawing Layout, Bill of Materials, Drawing Numbers
 3.6. Detail Drawing
 3.7. Assembly Drawing
 3.8. Practices of Detail and Assembly Drawing: V-block Clamp, Centering Cone, Couplings, Bearings, Antivibration Mounts, Stuffing Boxes, Screw Jacks, etc
4. **Computer Software Used in Drawings** (20 hrs)
 4.1. An introduction to CAD
 4.2. 2D Drawings in CAD
 4.3. Basic 3D Modeling in CAD

Practicals:

1. Isometric Drawings
2. Oblique Drawing
3. Perspective Projection
4. Limit Dimensioning and Machining Symbols
5. Threads, Bolts, Nuts, Welding and Riveting
6. Symbols for Different Engineering Fields
7. Detail Drawing
8. Assembly Drawing
9. Introduction to CAD software
10. 2D Drawings using CAD Software
11. Basic 3D Modeling with CAD Software

Final Examination Scheme:

Chapters	Marks	Remarks
1	10	
2	15	
3,4	15	
Total	40	



References:

1. Autodesk. (2010). *AutoCAD User's Guide*. Autodesk, Inc.
2. French, T., Vierck, C., & Foster, R. (1981). *Engineering Drawing and Graphic Technology*. McGraw Hill.
3. Giesecke, F., Mitchell, A., H.C, S., & Dygdone, J. (1986). *Technical Drawing, Eighth Edition*. Macmillan.
4. K.L.Narayana, P.Kannaiah, & Reddy, K. (2006). *Machine Drawing, Third Edition*. New Age International (P) Limited.
5. W.J.Luzadder. (1981). *Fundamentals of Engineering Drawing, Eighth Edition*. Prentice Hall.